

CX



Cubicool International is proud to launch its new CX - HD horizontal-discharge condensing units, for medium- and low-temperature applications.

These new generation units are weatherproof and supplied with fully integrated horizontal-discharge coated microchannel condensers, and speed controlled fans.

Standard units are fitted with energy-efficient Tecumseh reciprocating compressors and Copeland scroll compressors (digital and standard). Units are also fitted with standard line items.

Complete integrated electrical panel (compressors, condenser fans).

BENEFITS

- Cost effective
- Energy efficient
- Small footprint
- Tropical condenser selections
- Coated condensers



Cubicool International is committed to ensuring its products are designed, manufactured and assembled to operate in the most energy-efficient manner possible, using the latest available technologies and design methodologies in keeping with best industry practice

cubicool
i n t e r n a t i o n a l

CX - HD TYPE A

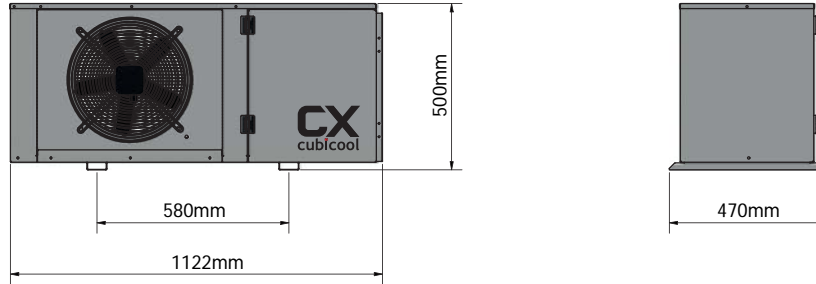

CX - HD TYPE B & C

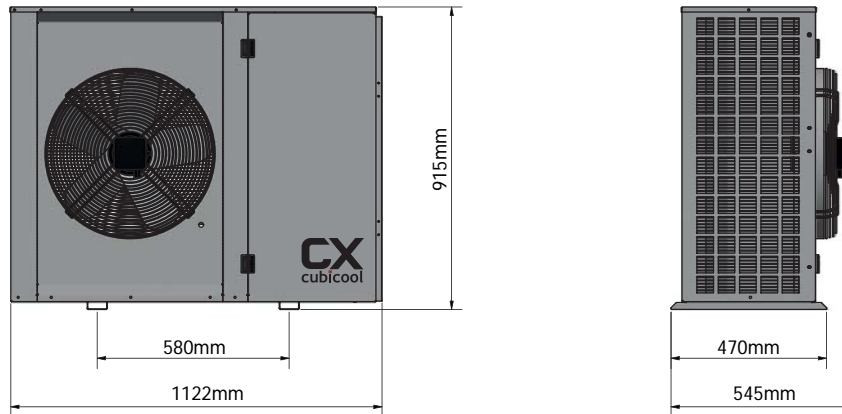

CX - HD TYPE D

